

江苏海大纺织机械股份有限公司

Jiangsu HaiDa Textile Machinery Co.,Ltd.

地址：江苏省无锡市新区梅村南丰工业配套园 B 区 A12、13 地块(梅村南丰一路 8 号)

ADD: No.8 Nanfeng First Road , Xinwu District, Wuxi, Jiangsu, China

邮编：214112

Postal code: 214112

电话：(0510)8855 9911

Tel: +86 510 8855 9911

传真：(0510)8501 1198

Fax: +86 510 8501 1198

邮箱：office@haidastenter.com

网址：www.haidastenter.com



官方网站

公众号

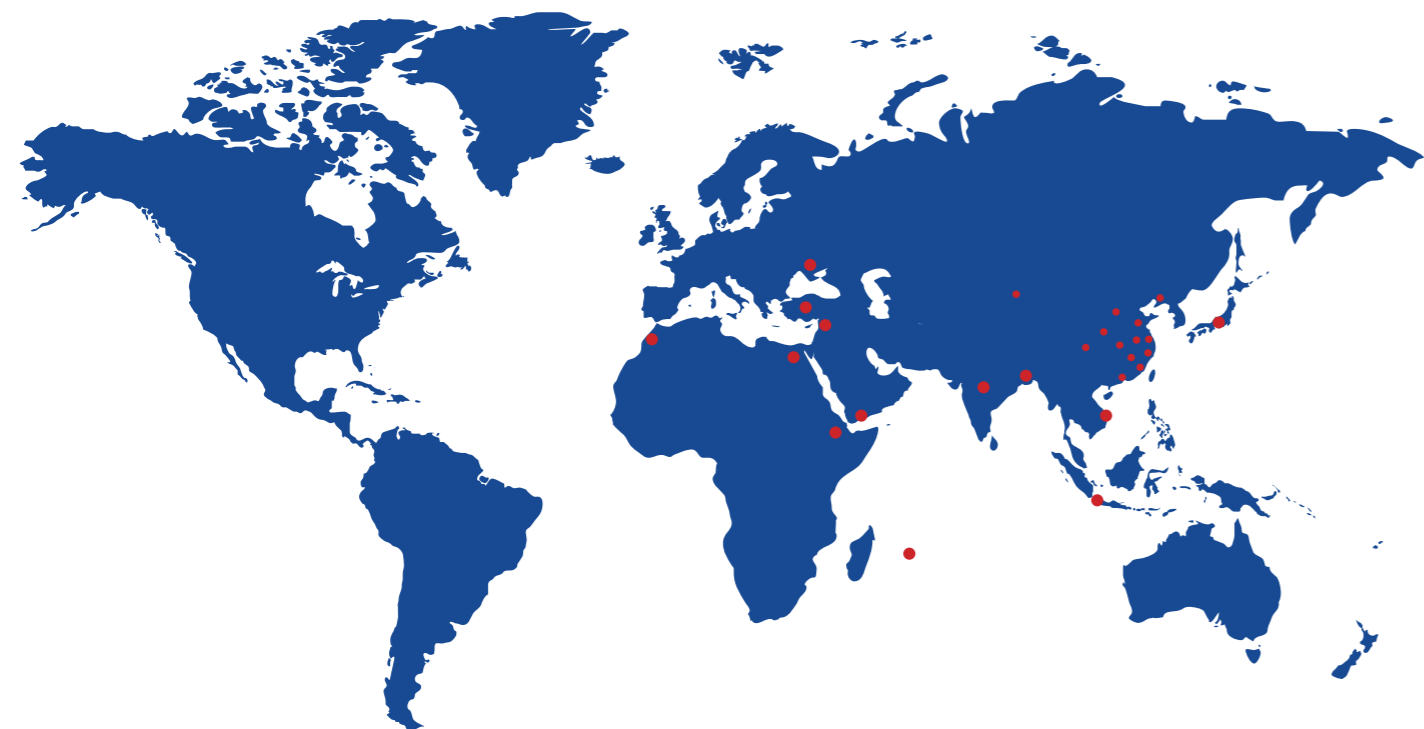

HAIDA 海大

COMPANY PROFILE

江苏海大自 1980 年创立起，一直致力于纺织定形机的研发及生产。海大从初期的生产专件到整机，从贴牌到独立研发，产品从多品种到专业化见证了定形机的发展史。

海大拥有富有创新的科研团队及经验丰富的精于实战的生产团队。近年来公司集中精力，研发生产新型环保节能的定形机，在行业中已具有较高的知名度。

在国内，海大是江苏省高新技术企业；是中国纺机行业印染机械分会会长单位；是中国纺织工程学会的“全国染整定形机，预缩机装备技术研发中心”，是“国家级博士后科研工作站企业分站”。

在国外，全球已有 14 个国家在使用海大的定形机。海大已授权国内外专利 148 项，发明专利 20 项，PCT 专利 4 项。

专业的设计，精湛的工艺，系统性解决方案提供者——海大。

Since its founding in 1980, Jiangsu HAIDA has been committed to the development and production of textile setting machines.

HAIDA from the initial production of profession parts to assembly of whole machine and from OEM to independent research and development to get own brand while the type of products trend to specialization.HAIDA's development milestone is also industry's growing history.

HAIDA has an innovative research team and professional skilled production team.

In recent years, HAIDA concentrates on the research and production of environmental protection and energy saving heat setting machine.

The new generation of ASMA503 Series achieved excellent performance in same industry.

In China,HAIDA is a high-tech enterprise in Jiangsu Province;is the head unit of China Textile Machinery Industry Printing and Dyeing Machinery association.

On the Haida premises the R&D centre of China Textile Engineering association for project of dyeing, finishing and pre-shrinking technology is located.

Haida textile machine are working in 14countries in the world.

Haida received 148 patents both in domestic and oversea; and 20 patents for invention and 4 PCT patents.

Professional design, precise technology, systematic solution provider — HAIDA



办公楼
Office building



生产车间
Work shop



实验室
Lab



生产设备
Manufacturing facilities

纺机工匠 产业报国——海大 40 年



Craftsman of textile machinery, repay our country with industry 40 years of Haida Company

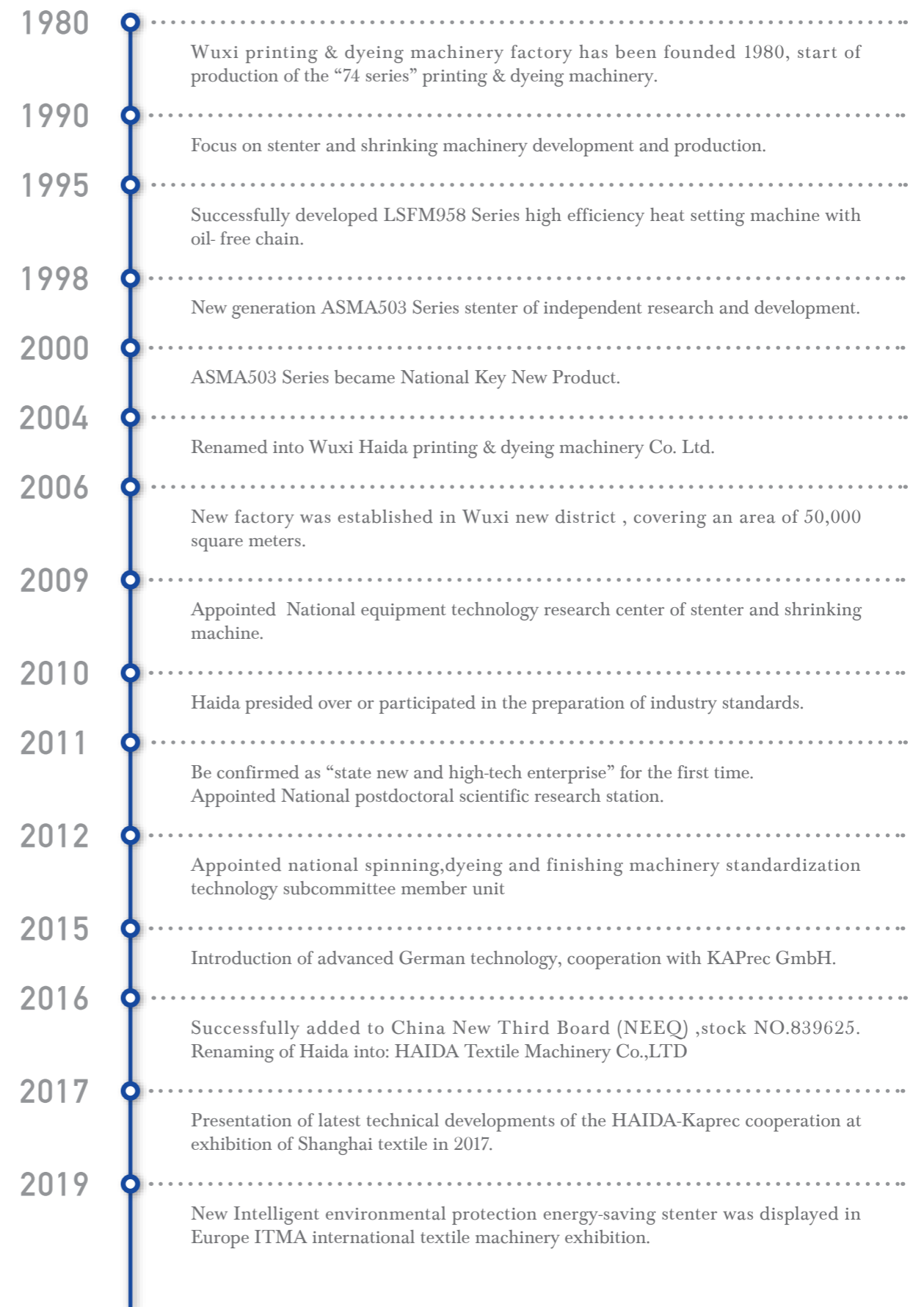

进布组合

Fabric infeed combinations



适合多类型织物的进布组合。由进布架、紧布装置、对中装置、张力控制组成，能满足各类织物的需要。
Applicable to various fabrics, it consists of fabric feeding stand, fabric with expanding, alignment device and tension control.

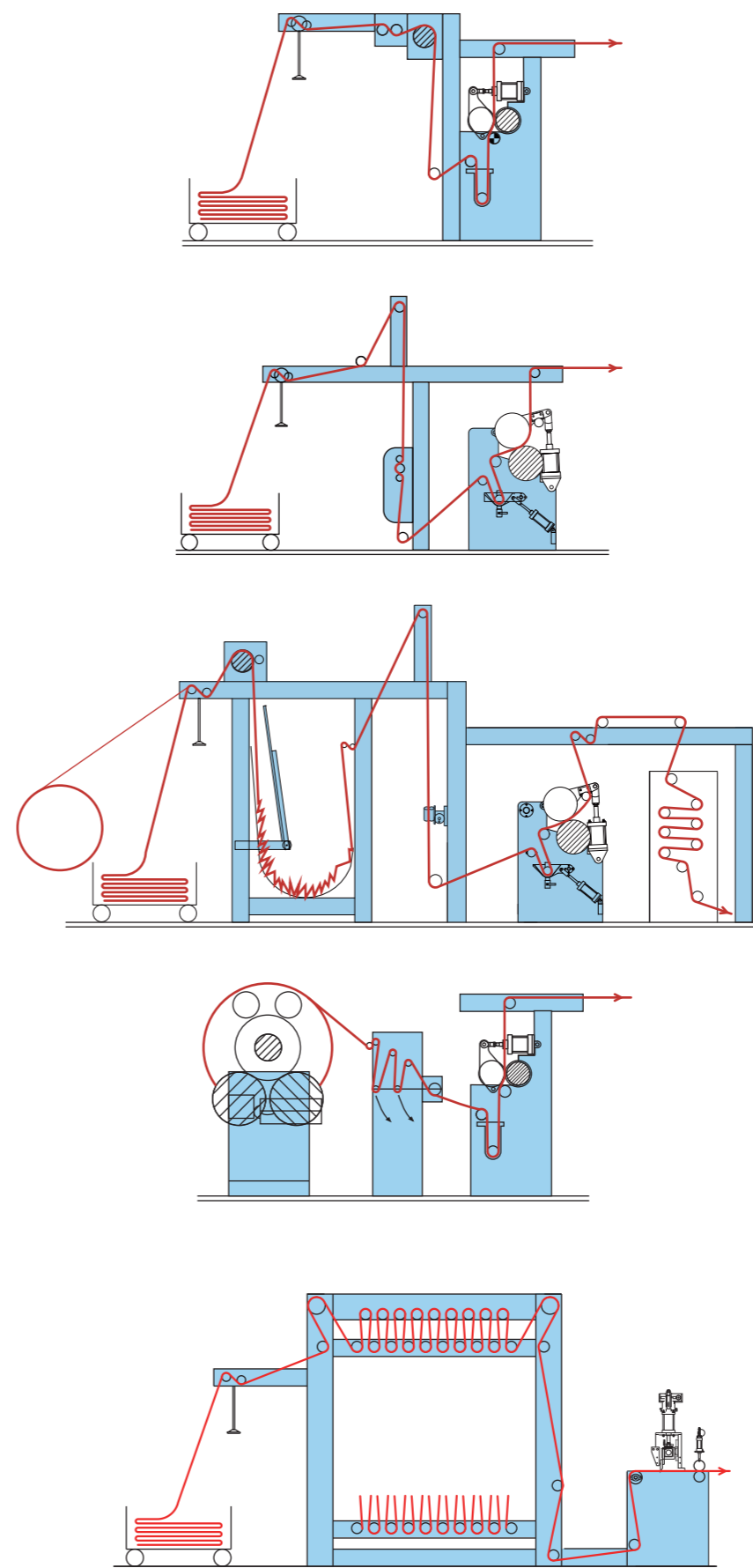

■ 适合针织物的进布组合装置
Fabric feeding combination for knitted fabrics

■ 适合梭织物进布组合装置
Fabric feeding combination for woven fabrics

■ 不停车换卷进布组合
Fabric feeding combination for non-stop batch change

■ 染经轴退卷
Fabric feeding combination for dyeing beam unwinder

■ 导辊式储布进布组合
Fabric feeding combination with roller accumulator

轧车

Padder

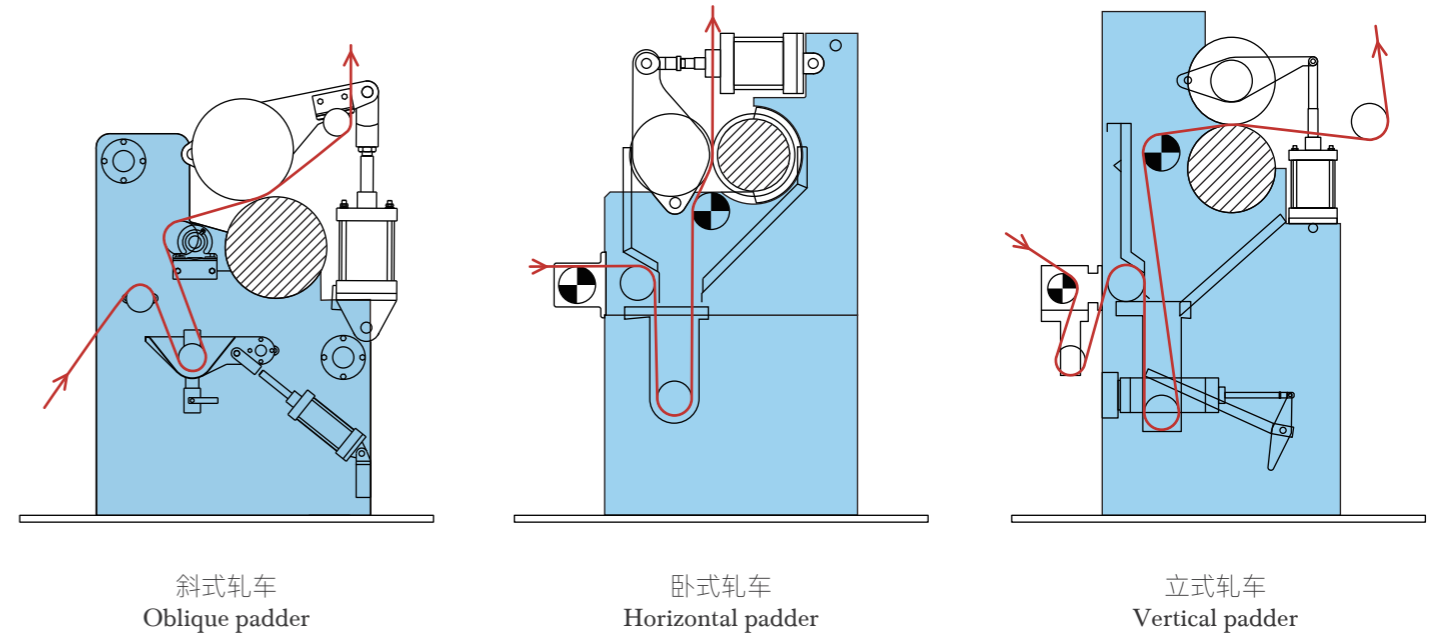

多种形式的轧车，满足各类织物的浸渍，轧水，轧液工艺需求。
Different types of Padder meet technical requirements for various fabrics and padding processes.

织物导程与液槽

Fabric lead and liquor trough

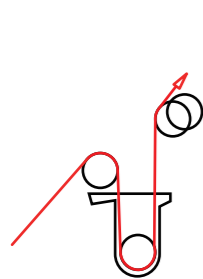

标准型液槽
Standardized liquor trough

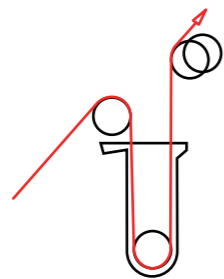

高容量液槽
High capacity liquor trough

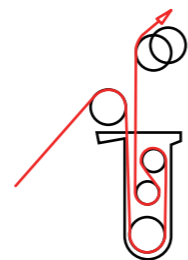

多导程液槽
Multi passage liquor trough

高效轧辊

High performance padder roller

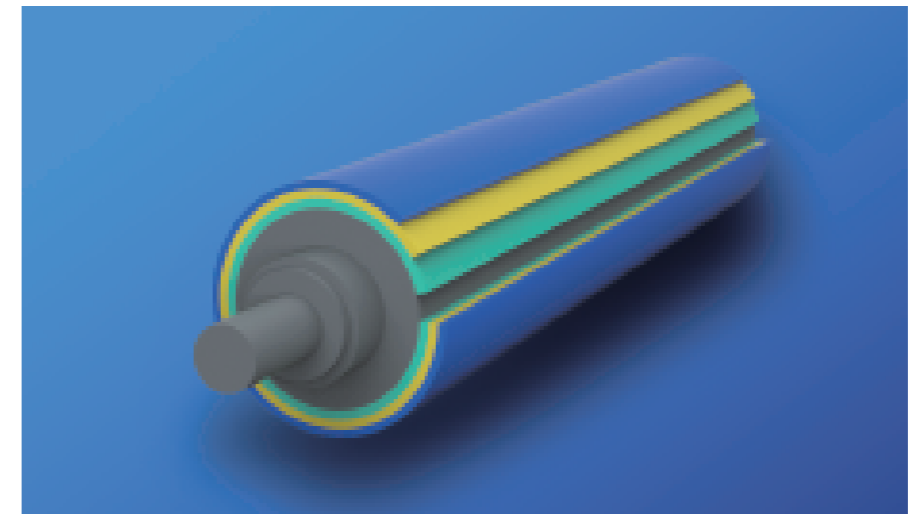

三层特制胶体，均匀挤压织物，轧余率接近脱水效果。
High performance padding bowl : 3 layers of special colloid, uniform pressure over the width , high efficiency of dehydration

超喂操作台

Overfeeding operation

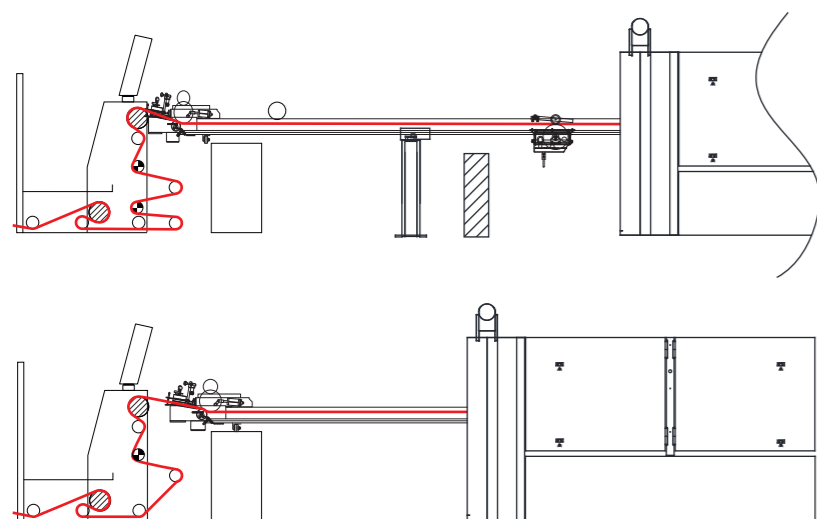

■ 针织超喂操作台
Overfeeding operating platform for knitted fabrics

■ 梭织超喂操作台
Overfeeding operating platform for woven fabrics

上下 2 次超喂，使结构松散的织物也能达到理想的喂入效果，适合各种织物的超喂率，左右布边张力可分别设定。

2 traction rollers individually driven by frequency controlled AC motors ensure an even fabric tension during the pin-in or clip-in process.

加长轨道区，可配置如浆边装置，蒸汽给湿装置等。

Extended stenter inlet section with steaming device and selvage glueing device is available as an option.

操作控制台

Operation platform



龙门架式
Overhead control bridge

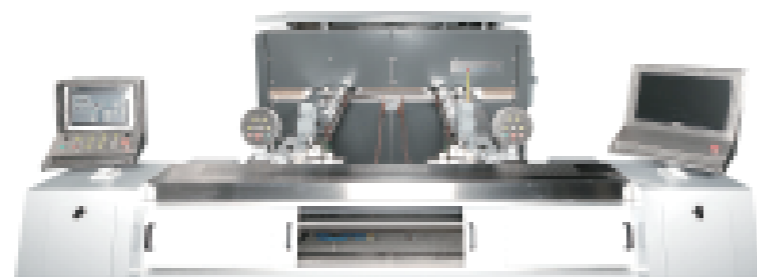

分体式
Split type

剥边超喂上针机构

Pinning unit with selvage uncurling device

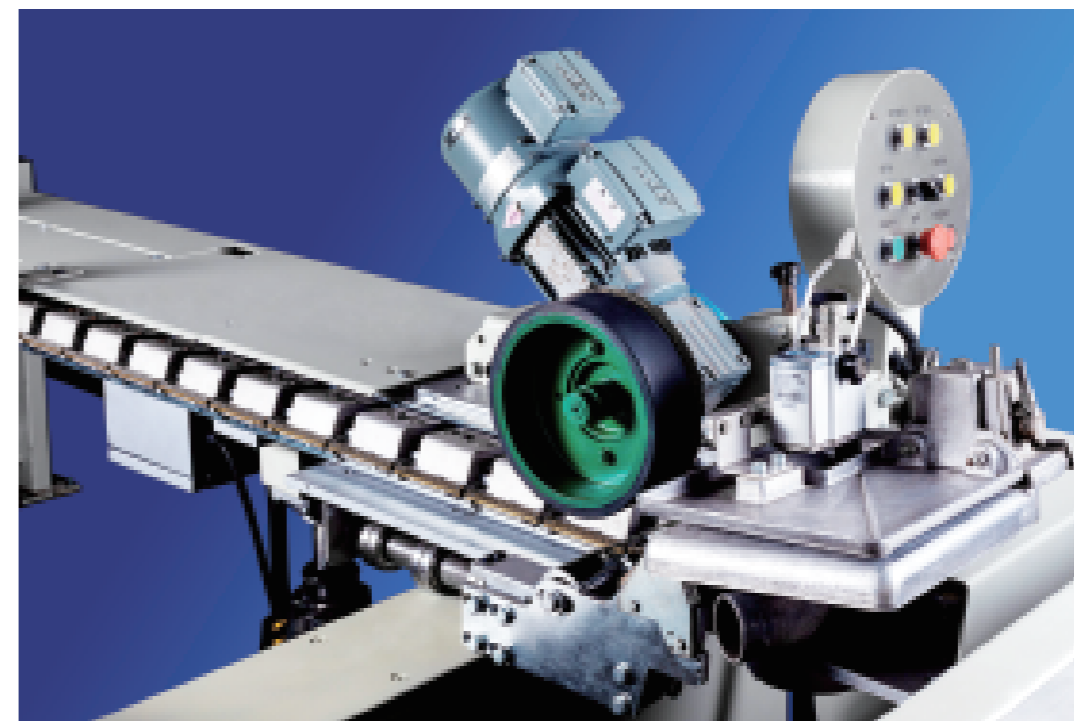

通过左右超喂毛刷橡胶轮同步上针，毛刷轮超喂可分别调节布边张力。

Synchronous pinning in the left and right stenter chain with rubber roller and pin-in brush. Left and right selvage tension can be adjusted individually.

上针超喂调整范围: -10% ~ +30%/60%/100%

Adjustment range of overfeeding: -10% ~ +30%/60%/100%



指式剥边 (分二, 三, 四指)
Finger uncurling
(2, 3 or 4 fingers)



板式剥边器
Plate uncurling



吹气剥边 (分单面、双面吹气)
Air blow uncurling

拉幅轨道

Stenter chain track

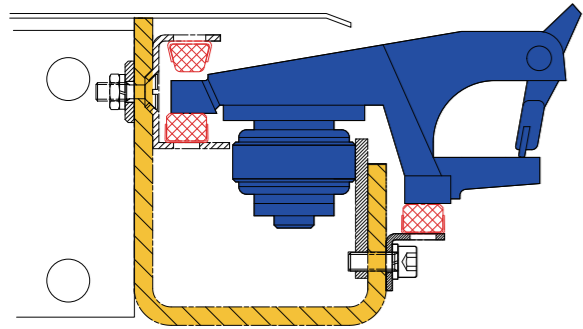

布铁
Clipchain link

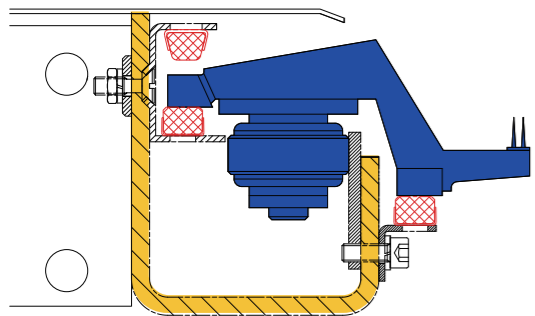

针板+防风保护
Pin chain link
with depinning protection
(option)

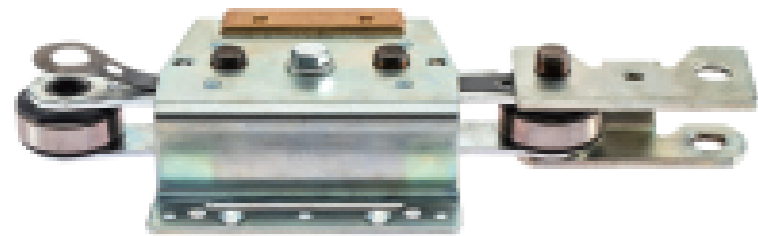

针座链条
Pin chain link with roller bearings



两用铁
Pin-clip chain link

可选轨道体形式

- 无油润滑轨道
- 铸铁加油轨道
- 无油润滑加强型轨道 (燕尾槽, 镶嵌润滑条)

幅宽调节系统

Width adjusting system

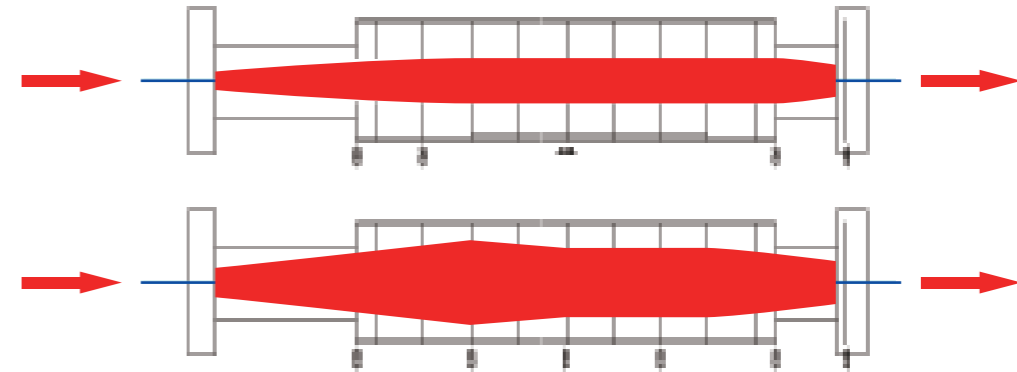

- 集体调幅方式: 进布端设一或二个单独电机调幅, 其余采用通轴调幅
General width adjustment of all spindles with longitudinal shaft, individual width adjustment in the inlet and outlet by motorized spindle.
- 独调幅方式: 每根调幅丝杆 有单独电机调幅
Individual width adjustment by motor of all width adjustment spindles.

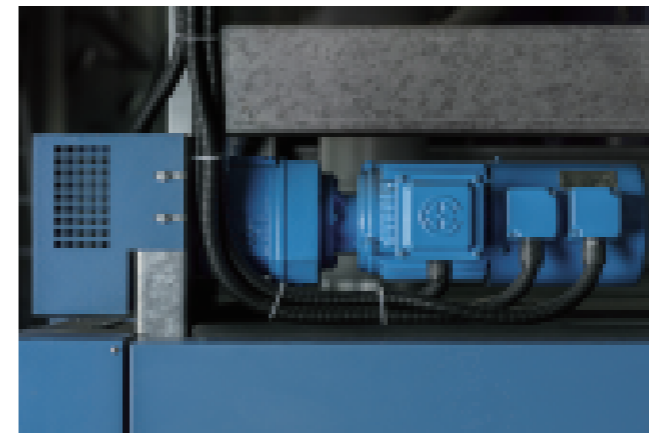

调幅电机
Width adjusting motor
直接电机编码器, 输出位置
Direct motor coder, position output.

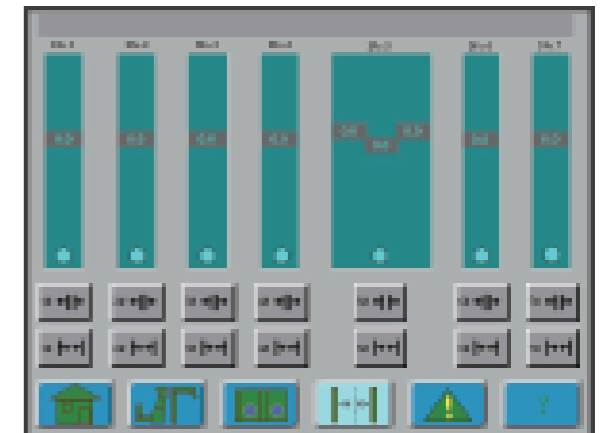

触摸屏控制
Touch screen control
调宽调窄可设定数字或点动, 相邻幅宽程序保护
Manual width adjustment on the touch screen or use of the set-up automation (option).

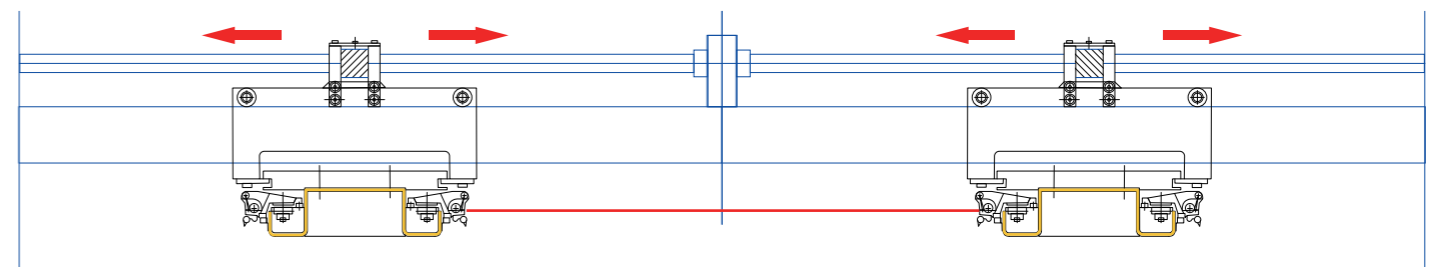

悬挂式轨道: 免加油, 维护方便
Hanging track: lubrication free, easy maintenance.

烘箱结构

Structure of chamber

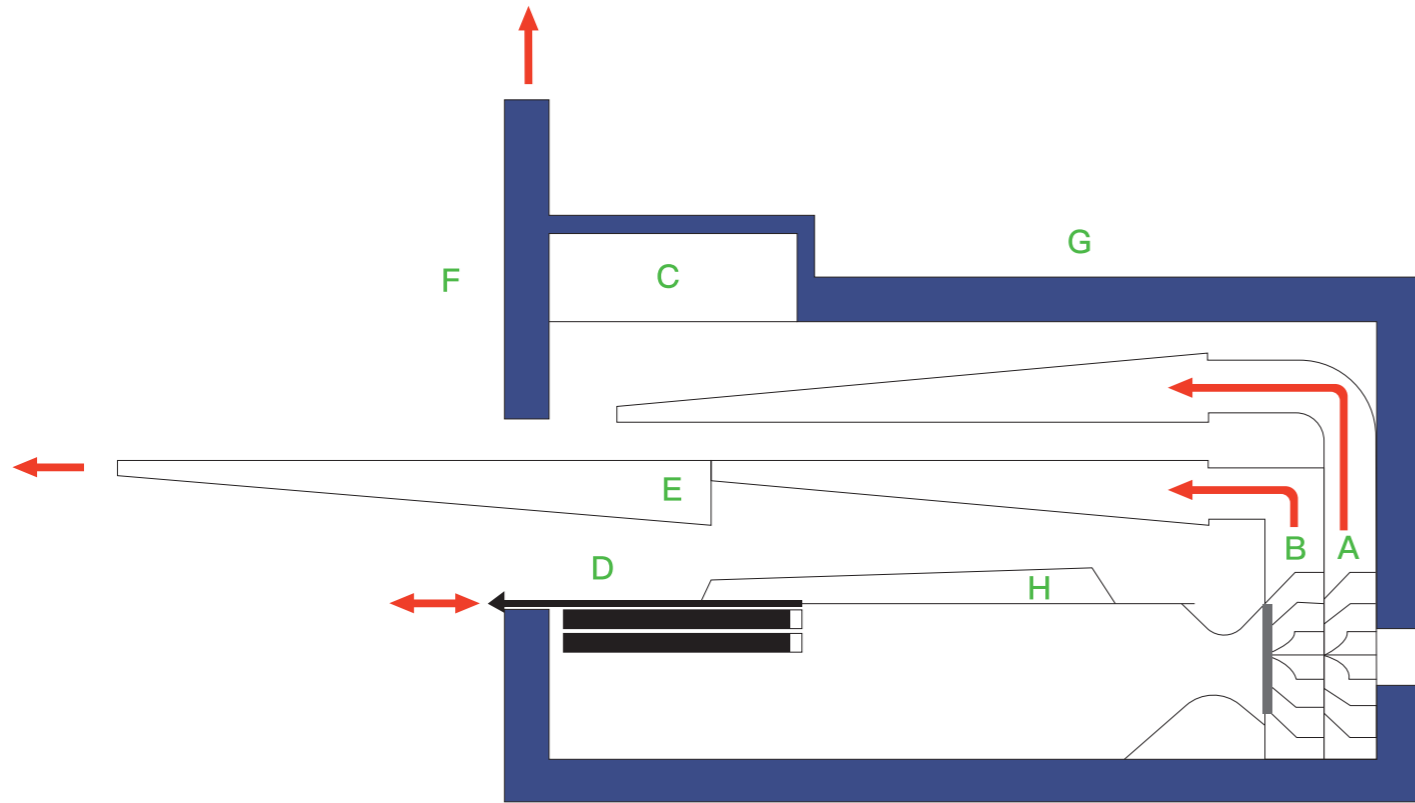

- A-B 上下风道气流量单独设定,在操作台可方便地调整和调节织物在烘房内的平衡
- C 内置排风系统
- D 过滤网可抽出清洁
- E 喷嘴易抽出清洁
- F 气动升降门
- G 150mm厚的隔热门板,保温性能高
- H 配备空气导流板,烘箱内气流更均匀

- A-B Independent upper and lower air flow thus the fabric balance can be easily adjusted from the operator panel (Twin-Stream)
- C Integrated exhaust duct
- D Lint filter can be cleaned from outside
- E Nozzles can be easily pulled out for cleaning
- F Pneumatic lifting doors
- G Energy conserving 150mm insulation
- H Return- air duct for the uniform return flow of the circulating air from the nozzle



烘箱进口气流屏蔽装置
Cold air barriers in the fabric inlet and outlet



可抽拉式滤网
The circulation air filters can be easily pulled out for cleaning during production



气动升降门, 减少对安装空间的需求, 提升热效率
Pneumatic lifting door, reduces space requirement increases the thermal efficiency

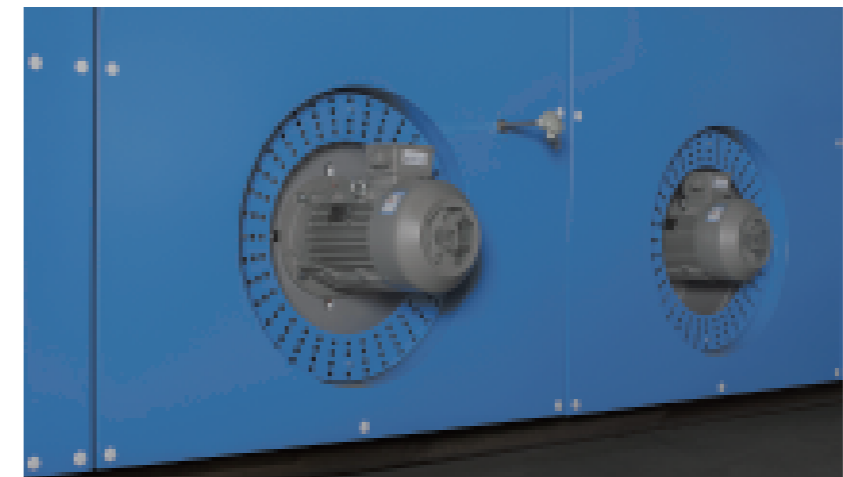

双风道循环
Circulating fan - twin stream

喷嘴系统

Nozzle system



适用于机织布的气垫式喷嘴系统
Air cushion type nozzle system for woven fabric

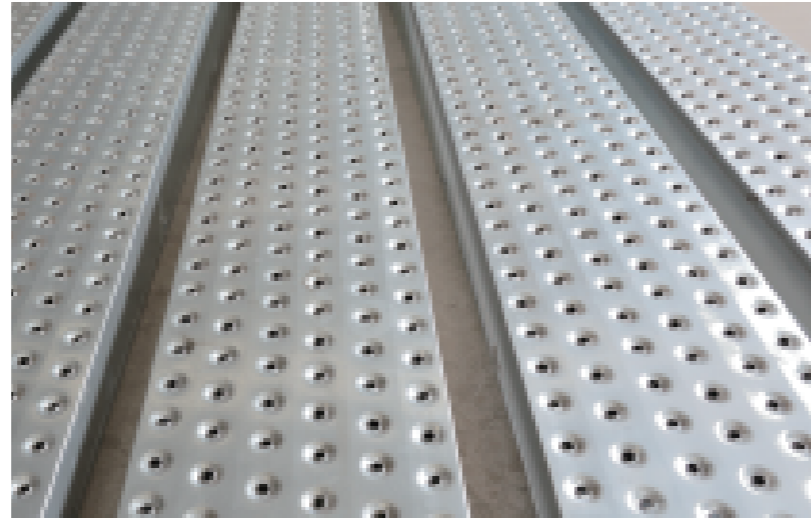

适用于敏感织物的喷嘴系统
Special nozzle system for sensitive fabric



适用于针织布的气垫式喷嘴系统
Air cushion type nozzle system for knitted fabric

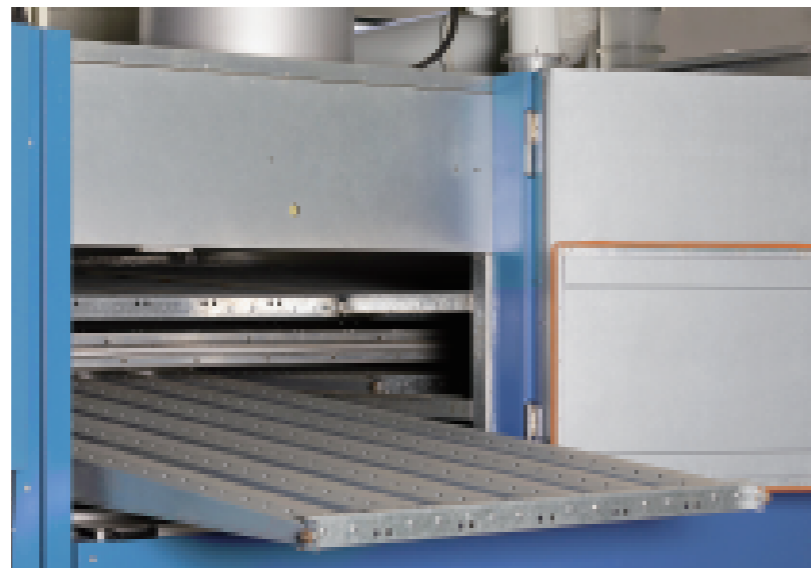

可抽拉式风嘴
Drawer-type nozzle

热源系统

Heating sources system

可选热源

- 燃气 (液化石油气, 天然气)
- 蒸汽 (中低压)
- 载热油
- 电

Heating sources

- Gas (liquefied petroleum gas, natural gas)
- Steam (middle or low pressure)
- Heat transfer oil (thermo oil)
- Electricity



导热油加热
Thermo-oil heating

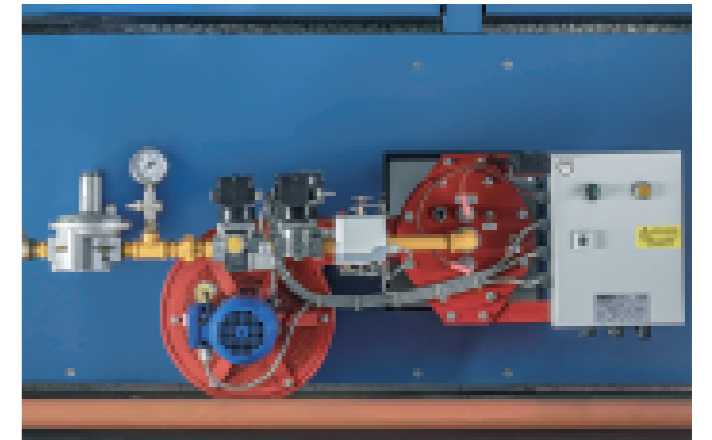

天然气加热
Gas heating

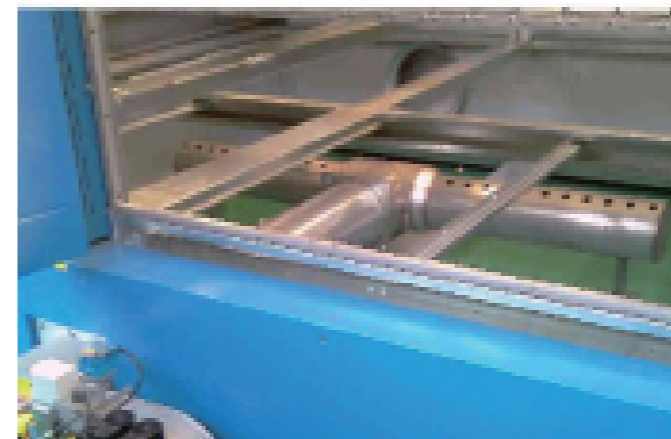

天然气直接加热
Gas direct heating

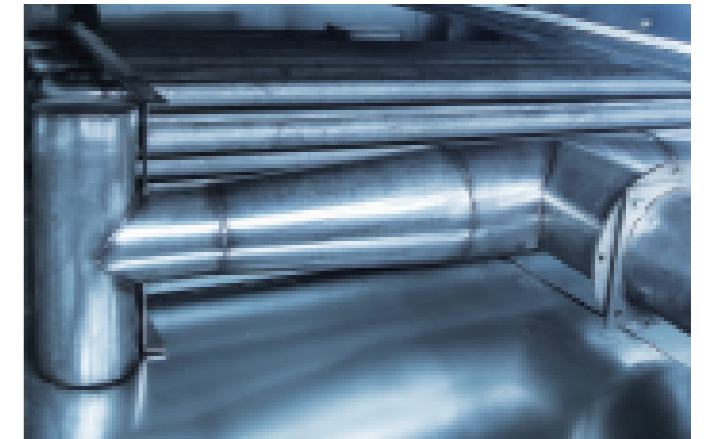

天然气间接加热
Gas indirect heating

ASMA503 系列定形机

ASMA503 SERIE stenter

定形机可通过脱水、烘干、焙烘、整理,来改善织物的手感、滑移、颜色、幅宽、强力、外观等;对非织物品种,还可以起到稳定尺寸的作用。

Multi purpose stenter for drying, heatsetting, width setting and curing of various types of fabrics and nonwovens.

主要技术参数

Main technical parameters

- **形式**
热风循环, 单层卧式
- **车别**
分左右型
- **公称宽度 (mm)**
1800,2000,2200,2400,2600,2800,3000,3200,3400,3600~5500
- **调幅范围 (mm)**
450~公称宽度-200
- **热源**
燃气 (液化石油气, 天然气) / 蒸汽 (中低压) / 载热油 / 电
- **配置**
3~12节烘箱
- **Basic design**
3m chamber units with hot air circulation
- **Machine type**
Countertype installation
- **Working width (mm)**
1800,2000,2200,2400,2600,2800,3000,3200,3400,3600~5500
- **Minimum working width (mm)**
450
- **Heat source**
Gas (liquefied petroleum gas, natural gas)/Steam (middle and low pressure)/Thermo oil/Electricity
- **Layout**
3-12 chambers

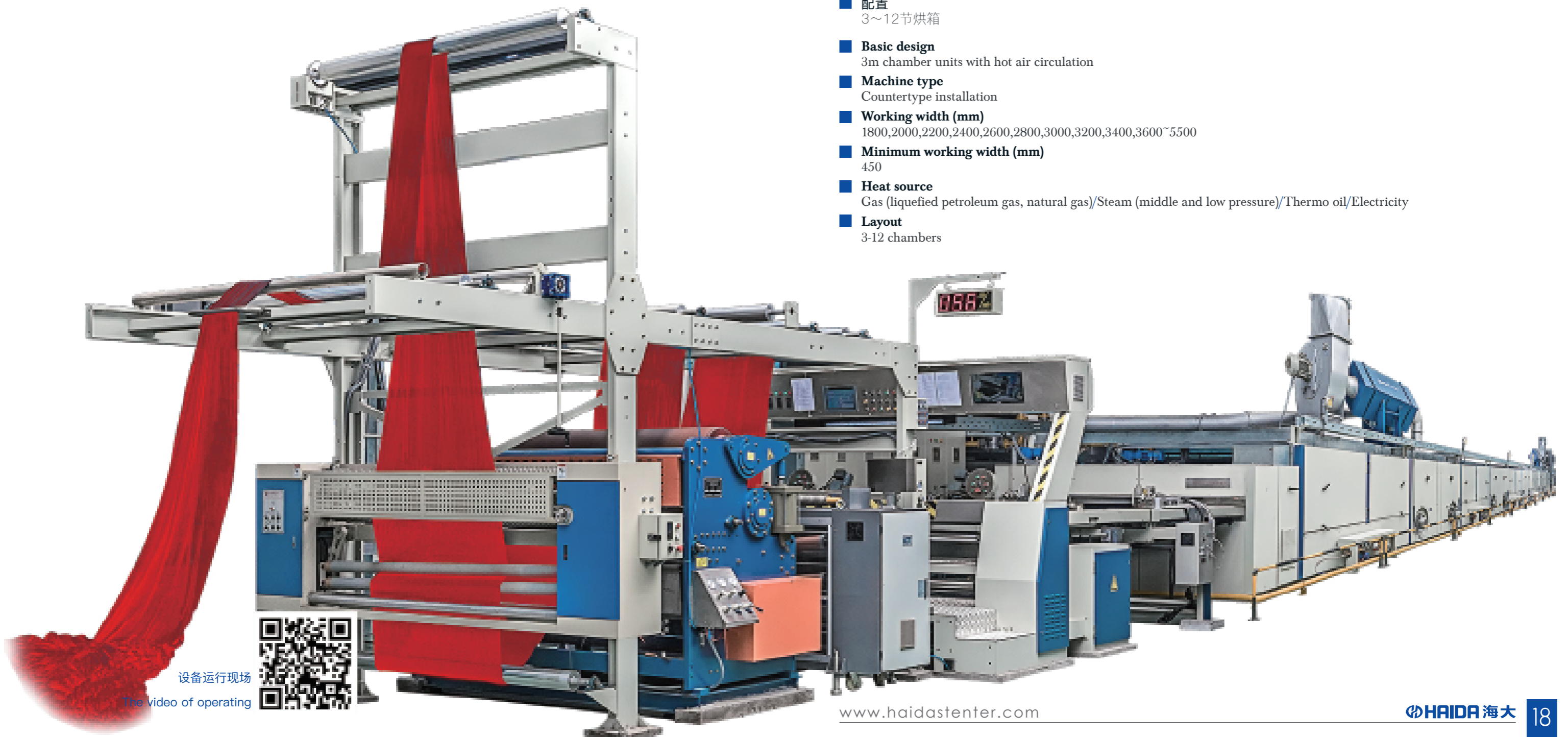

设备运行现场

The video of operating

www.haidastenter.com

HAIDA 海大

出布组合

Fabric outlet combinations



出布超喂，冷水辊，落布，摆布，打卷各单元单独电机控制。
 Outlet combination with air cooling device, plaiter and batcher with separate drive.

选购 (Options):

出布给湿装置
 Fabric humidifier at the outlet

出布搓边装置
 Antistatic device

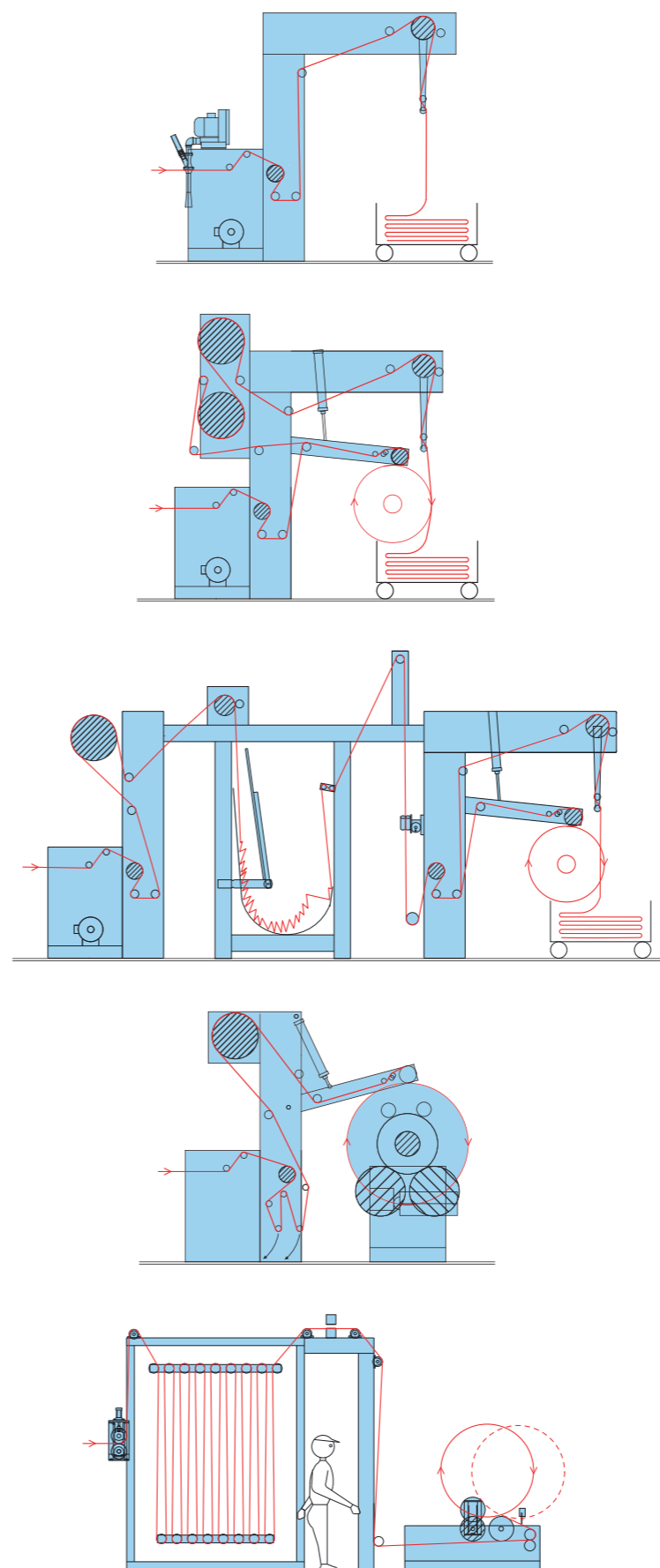

■ 适用针织布の出布组合
 Fabric outlet combination applicable to knitted fabrics

■ 适用梭织布の出布组合
 Fabric outlet combination applicable to woven fabrics

■ 不停车换卷出布组合
 For non-stop batch change with fabric collecting scray

■ 经编织物出布组合
 Fabric outlet combination with dye beam winder

■ 导辊式储布出布组合
 Outlet with roller accumulator for non-stop batch change

经典案例，流程图

Typical cases, process chart

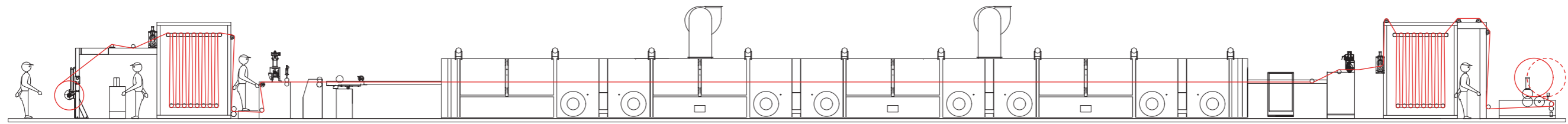

■ 毯类织物烘干定形机 Drying stenter for blanket fabric (non-stop batch change with roller accumulator)

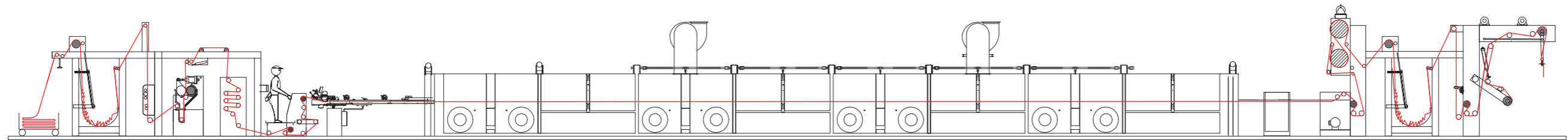

■ 不停车连续生产形式 Non-stop continuous production with fabric collecting scray

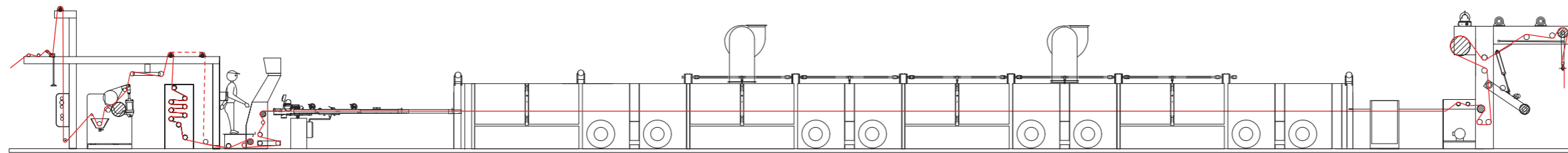

■ 梭织拉幅定形机 Stenter for woven fabric

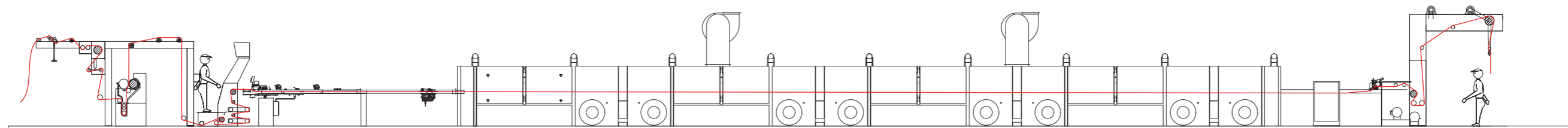

■ 针织物定形机 Stenter for knitted fabric

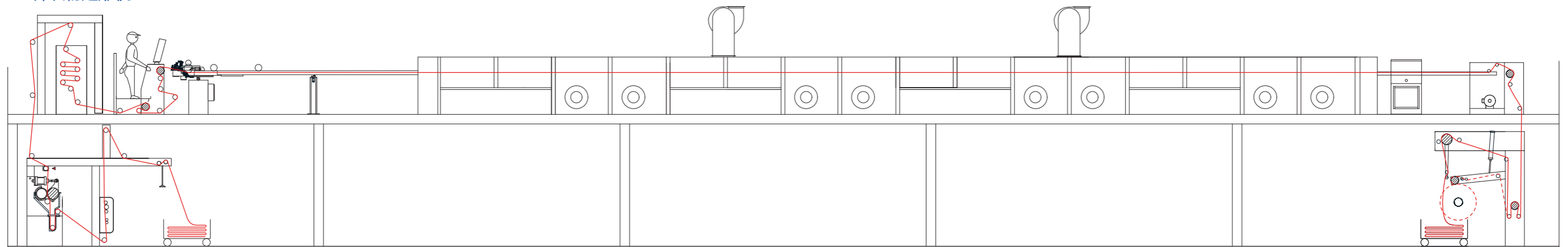

■ 平台安装定形机 Stenter on platform

电气控制

Electric control

可视化触摸屏操作界面，数据可重演。电脑辅助监察及控制系统，高效，低成本运行，使定形时间与生产速度最优化；防定形过度烘干，降低生产成本，与人工控制，此系统重现性好。

Programmable logic process controller (PLC). Expandable and adaptable for practically all tasks arising in modern textile finishing like:

Integration of setting values for measuring and control devices.

Batch management

Network interfacing

Prepared for teleservice

Maintenance manager

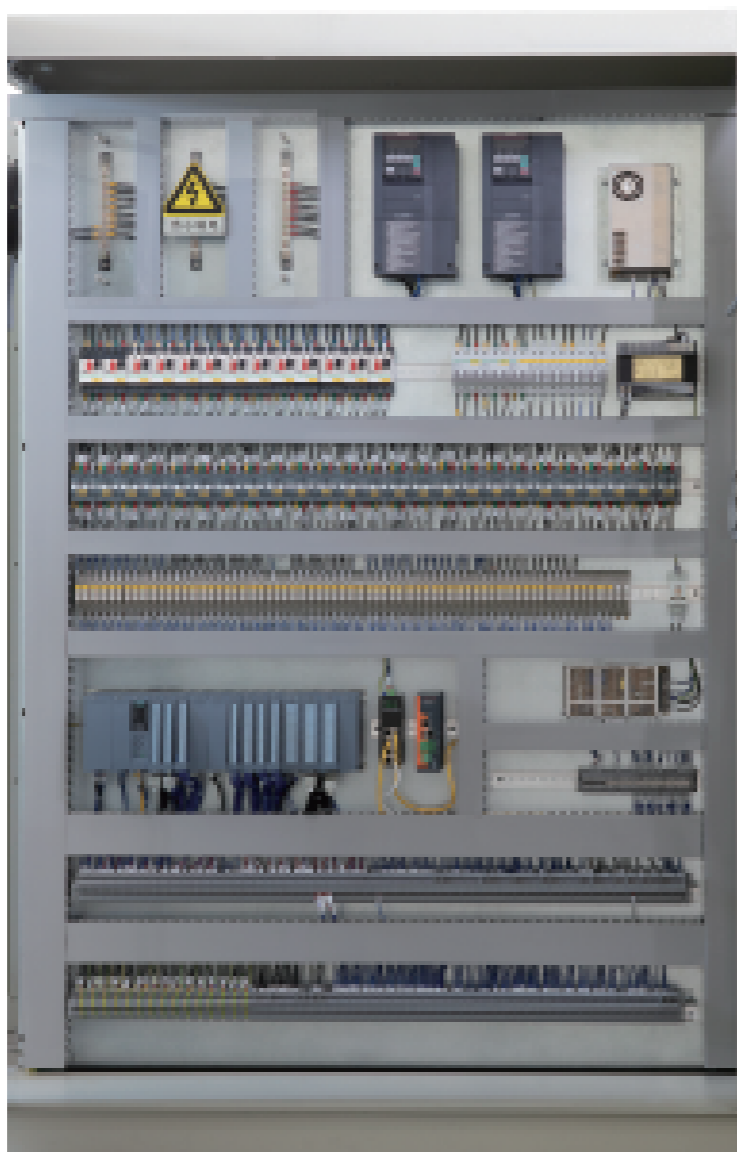

单体电柜内部
Interior of electric cabinet



整体电柜
Electric cabinet

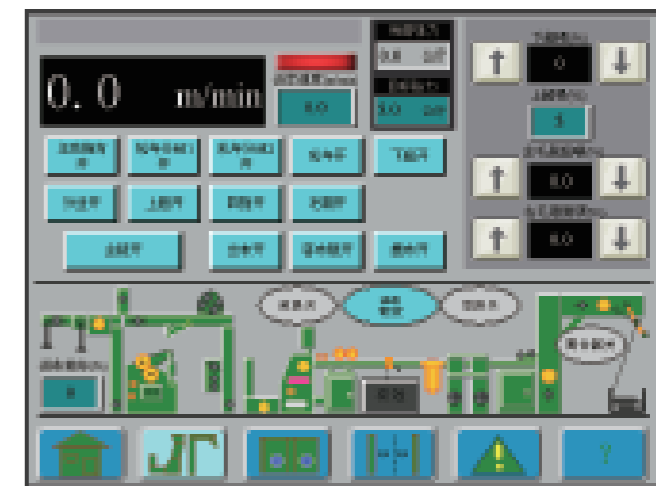
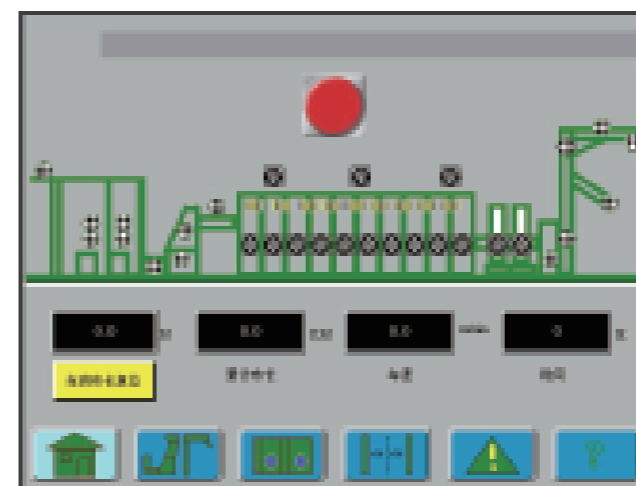

触摸屏操控界面
Touch screen machine adjustment and control

主传动装置

Master drive

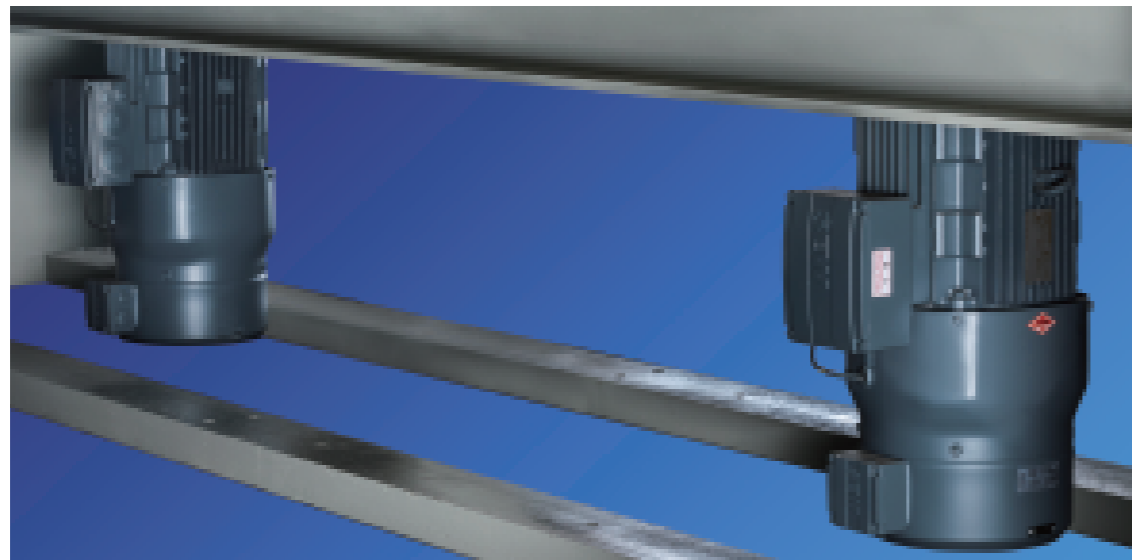

双电机驱动
Drive by two motors

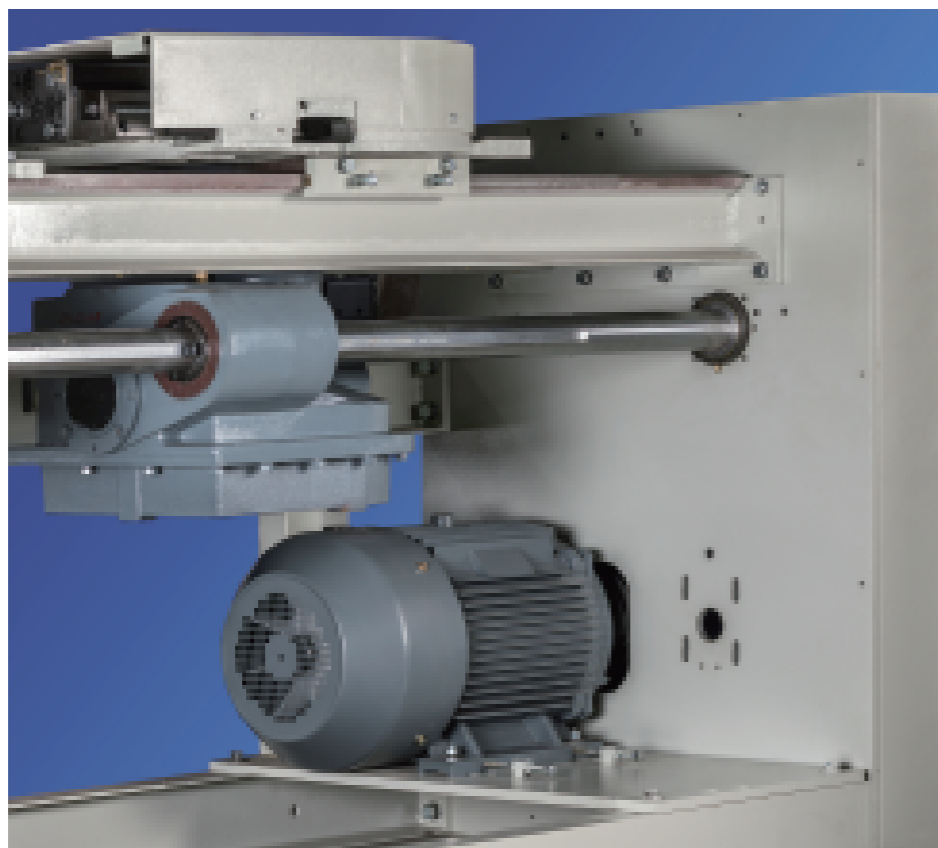

单电机驱动
Drive by single motor

远程运维

Remote operation

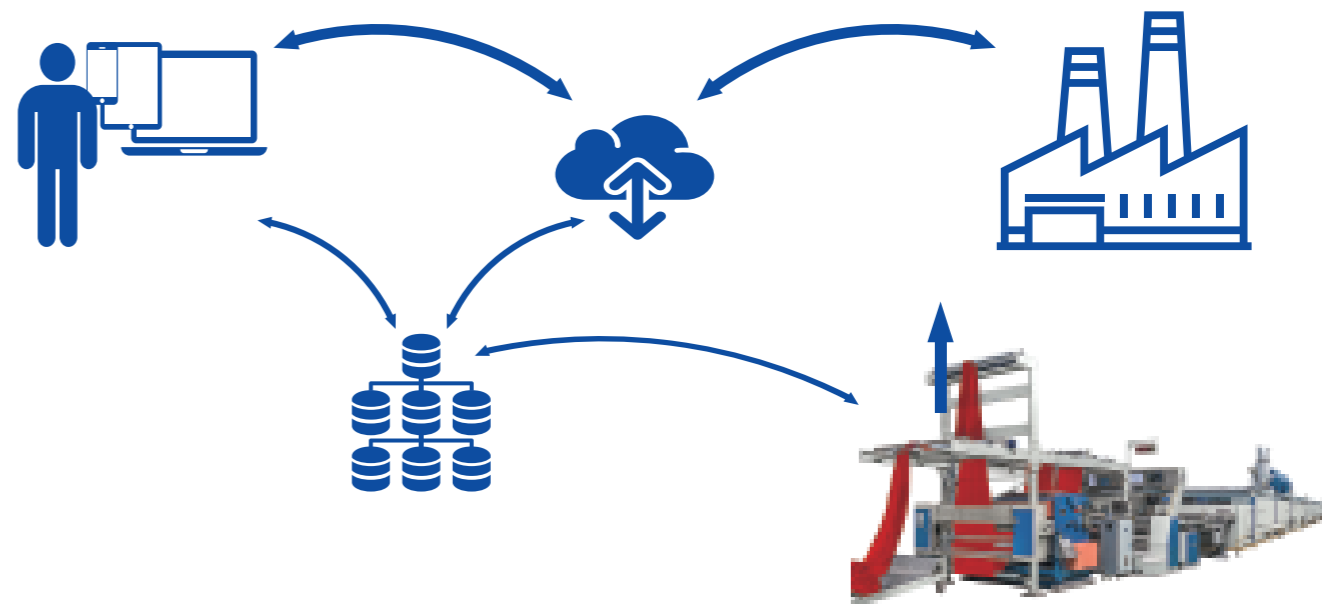

可以通过电脑、手机小程序，随时随地查看设备的运行数据。

Check operating data of the equipment at any time with computer or mobile phone.

能耗管理，提高能源利用效率。

Manage energy consumption and improve energy efficiency.

统计设定时间段内能耗的数据。

Statistics of energy consumption in a given period.

质量追溯，提升工艺水平和产出效率。

Trace quality problems, upgrade technical level and output efficiency.

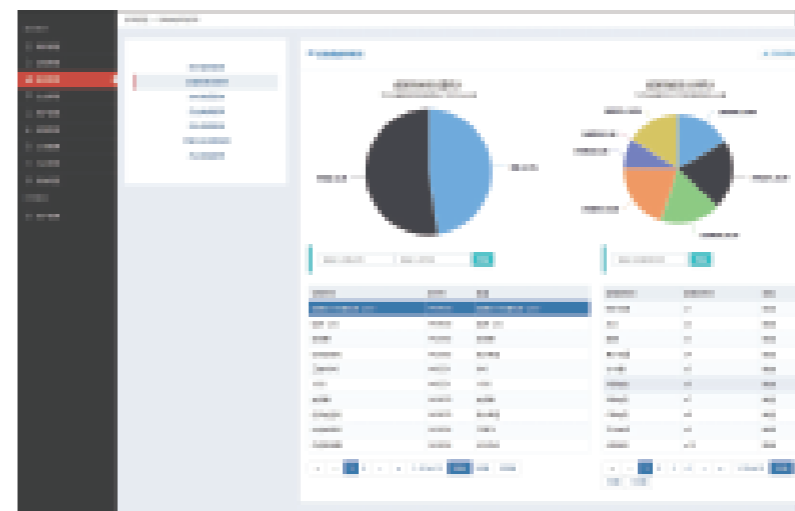

烘箱选配

Optional in the chamber

旁通系统

Air-bypass system

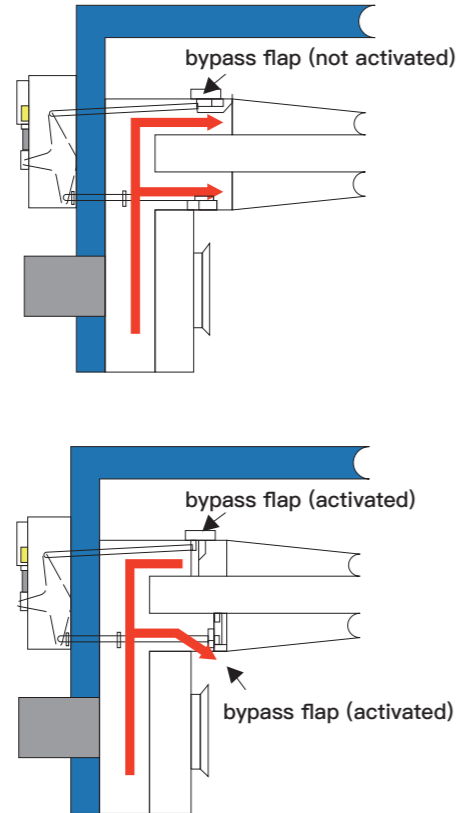
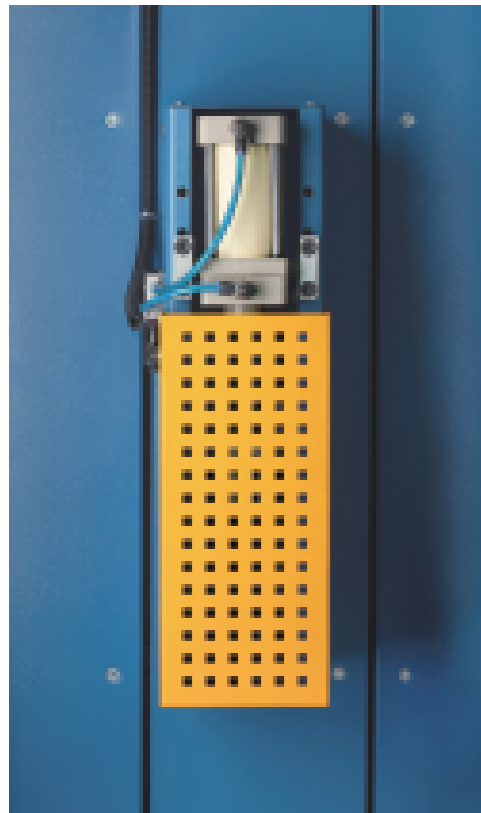

旁通系统可以使定形机在短暂停机时阻止来自喷嘴的热风对布面造成损伤

The air-bypass prevents the air flow from impinging on the fabric during machine stop. The treatment temperature in the chamber will not decline. After restart the fabric will be treated immediately with the adjusted operation temperature. The bypass is operated pneumatically from the outside of the chamber.

回流导向系统

Return-air guiding system

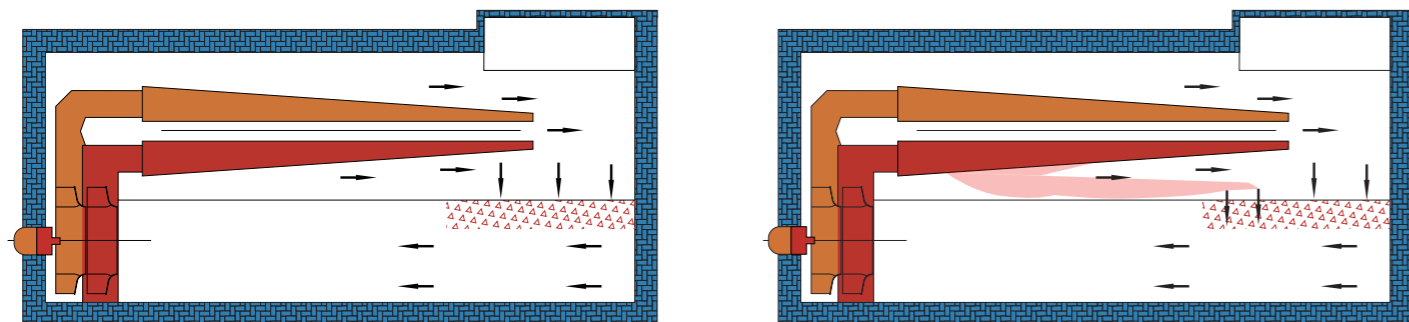

定形机全幅排气的回流导向管设计用于敏感型织物

The return-air guiding duct exhausts the air flow over the full width of the machine thus better results for delicate and elastic fabrics will be achieved.

自动清洁滤网装置

Automatic filter cleaner

旋转清洁

Rotating cleaning



使用旋转滤网将不会因为滤网堵塞而产生的定形机效率减少。

Automatic filter cleaning will keep the stenter efficiency permanently on the optimum level.

滤网和毛絮集尘箱

Filter screen and floc dust collection box



选配单元

Optional unit

在线检测

Online detection

在定形机运行使用中, 在线检测设备可随时检测纬密(克重检测)、排气湿度、布面温度、烘房湿度, 布面含湿度。

During the stenter process the online detection permanently controls selected operation data and corrects the adjustment if set-limits are exceeded.

■ 纬密检测 (克重检测) Weft density (gram-mass) detection

进布、出布摄像扫描传感器, 精确得到单位面积内的经纬纱数量, “入口预制+出口检测反馈”, 目标值补偿确保织物稳定纬密值上针并进入烘房进行定形。

A sensor at the inlet and exit of the stenter detects the number of threads(weft) and displays it on the stenter control monitor. Depending on the fabric character off-limits can be corrected by automatic overfeed adjustment

■ 布面温度检测 Fabric temperature measurement

在定形过程中, 织物温度变化会形成一条升温曲线, 布温感应器M1\M2\M3, 配合定形时间, 决定定形机生产速度。

The fabric temperature profile will be ascertained with temperature sensors, thus indicating the begin of the heatsetting process. The operator can preselect the heatsetting time (s) and the computer will indicate the suitable production speed.

■ 布面含湿度检测 Fabric moisture measurement

滚轮式传感器, 接触布面精确测量导电性, 计算出含湿率。

Sensors detect the residual moisture of the fabric at the outlet of the stenter. depending on the fabric properties the speed of the stenter or the operation temperature can be adjusted accordingly.

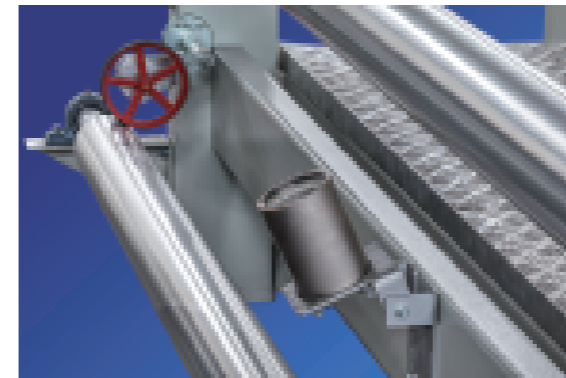

■ 排气湿度检测 Detect exhaust humidity

使用耐高温传感器, 在线检测废气含氧量, 计算出含湿率, 根据检测值与目标值差异控制排风提高或降低运转负荷, 从而达到节约热能, 节约电能的目的。

A heatproof sensor determines the exhaust humidity (water-vapour) in the exhaust air duct of the stenter. The amount of water vapour influences production speed and energy consumption of the stenter. The speed of the exhaust fan will be automatically adjusted to keep the exhaust humidity on an economic level.

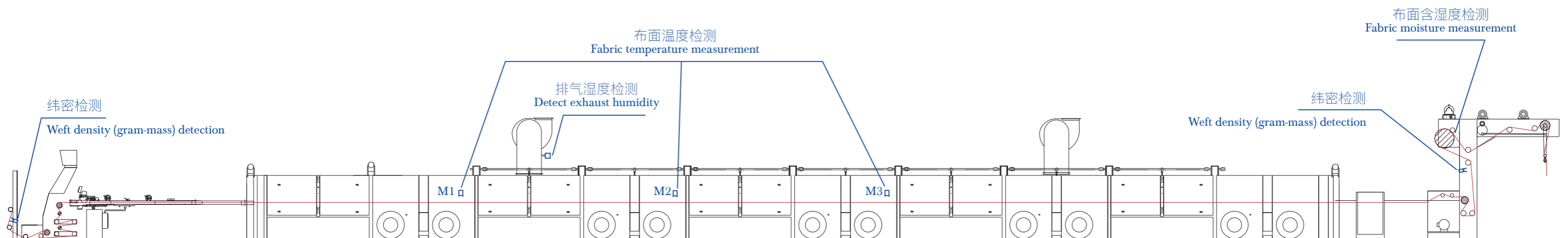

余热回收

Heat recovery of exhaust

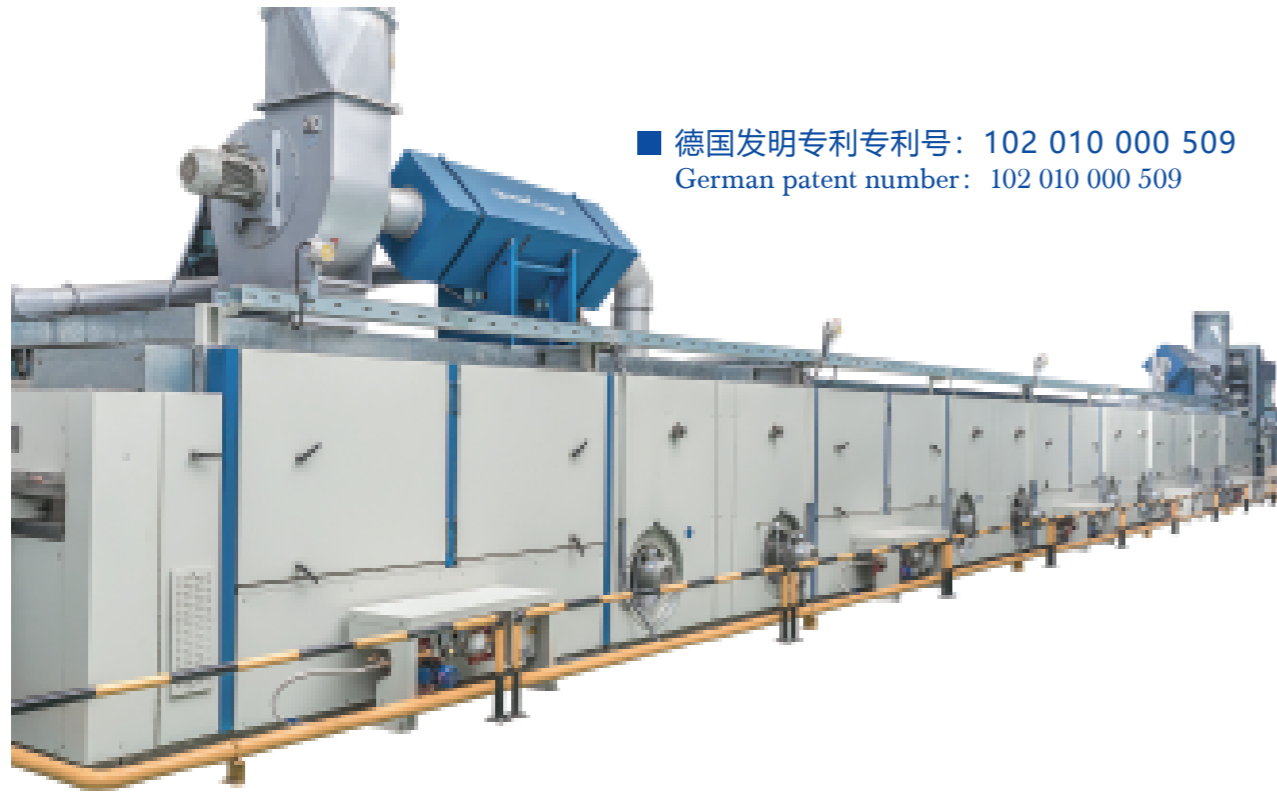

德国发明专利专利号: 102 010 000 509
German patent number: 102 010 000 509

定形机运行过程中, 产生废气的温度达到 140 度到 200 度, 安装此废热回收装置, 能将排出的废热, 转为加热新鲜空气, 补充给定形机使用。经济有效, 安装维护方便。

In the process of production, temperature of waste gas reaches 140-200°C, this waste heat recovery unit can use waste heat to preheat the process air for the stnter, thus saving up to 30% of energy. Economical and effective, easy to install and maintain.

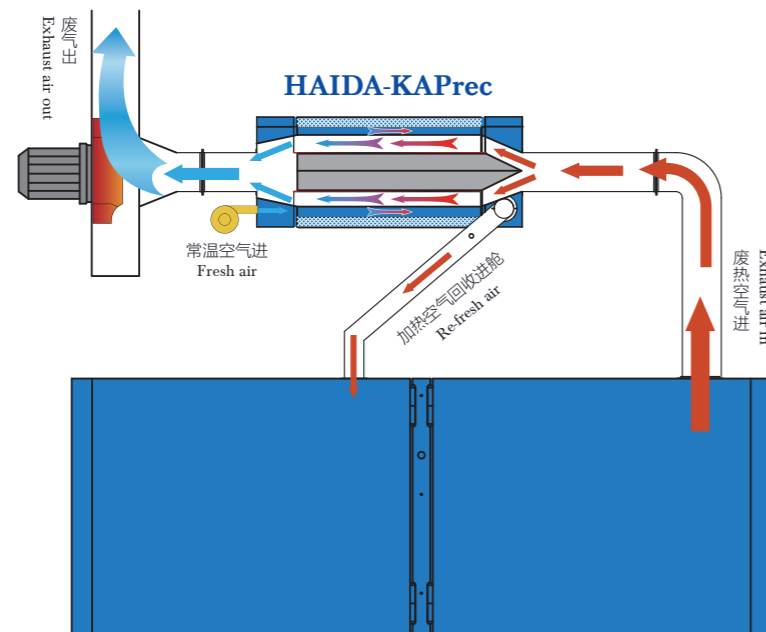

实施方案

Kaprec thermo shield

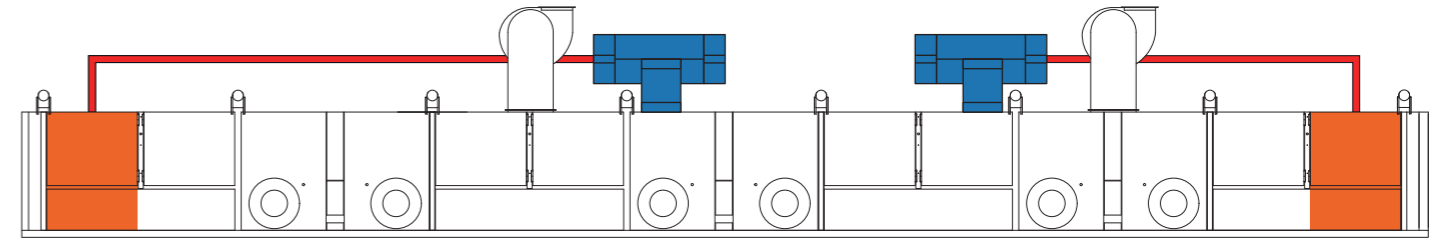

分别使用2个余热回收将加热后的新风送至第一节和最后一节烘房
使首末烘房内的温度更加稳定
减少从室外进入的新风量

2 HAIDA-KAPrec heatrecoveries deliver heated-up fresh air to the first and the last chamber
Better temperature stability in these chambers
Reducing the amount of fresh air needed from the outside

清洗维护

Maintenance

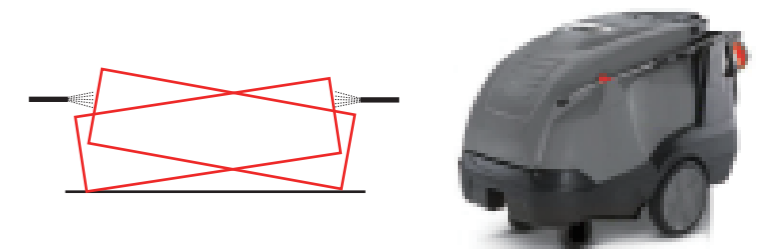
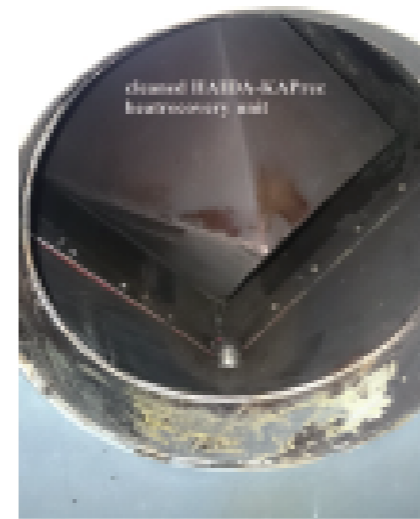

将该装置倾斜放置并用清洁装置从两头进行清洗
Place the heat recovery in a skew position and clean with a high pressure cleaning device from both sides

针织专用件

Special for knitted fabrics



横动板条式对中
Traverse slat alignment

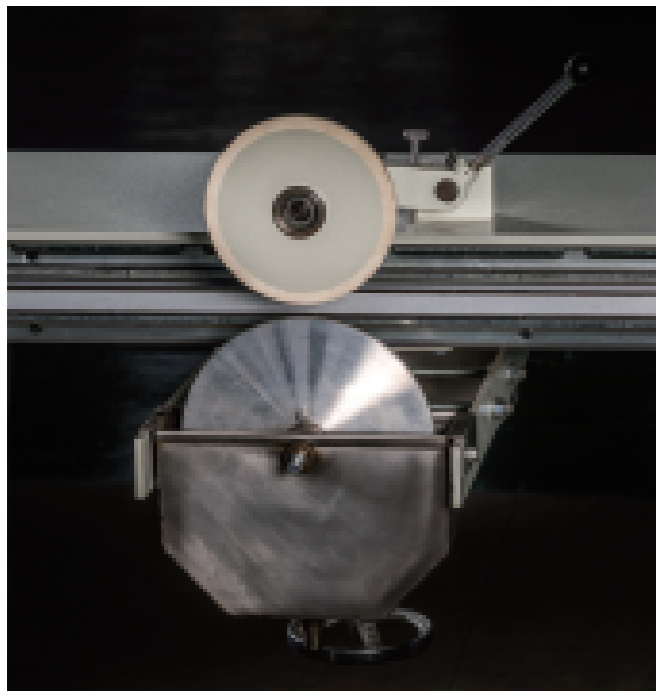

浆边装置
Selvedge glueing device



切边吸边装置
Edge cutting and discharging device

选配装置

Optional device

- 整纬机
- 浆边装置切边装置
- 清洁针板装置
- 出布给湿装置
- 燃气报警装置
- 电柜外置空调
- 纬密检测（克重检测）
- 布面温度检测
- 布面含湿度检测
- 排气湿度检测
- 远程控制
- ERP 端口
- 能源计量系统
- 出布搓边装置
- Weft straightener
- Selvedge glueing device & selvedge trimmer
- Needle plate cleaner
- Fabric humidifier at the outlet
- Gas alarming
- Air conditioner of electric cabinet
- Weft density (gram-mass) detection
- Fabric temperature measurement
- Fabric moisture measurement
- Detect exhaust humidity
- Remote control
- ERP port
- Energy measurement system
- Antistatic device